

Instruction for work
Betriebsanleitung
List of spare parts
Ersatzteilliste



SIP

ROTO 170D

rotary disc mower scheibenmäher

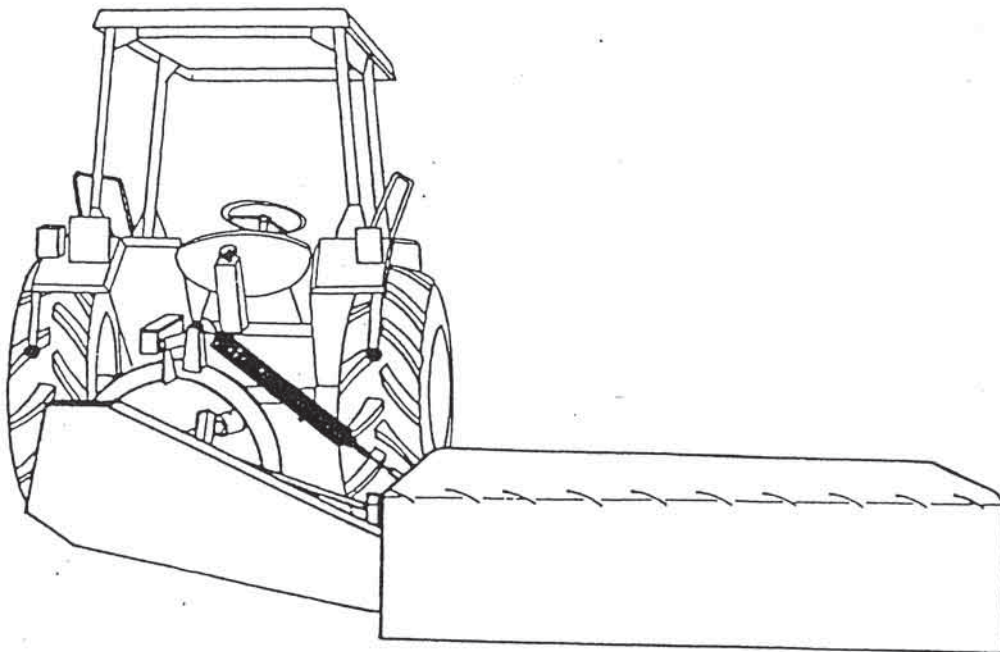

Ab masch Nr.:
From mach Nr.:
ROTO 170 D = 261



SIP

STROJNA INDUSTRIJA d.d.
3311 Šempeter v Savinjski dolini
Slovenija

Tel: +386 (03) 7038 500
Fax: +386 (03) 7038 663
+386 (03) 7038 674

No.on the figure Numer anzeichn.	Catalogue no. Katalog nummer	Description	Benennung	Quantity Stück
1	153145509-535.04.001.0	Tube	Rohr schw.	1
2	152154216-520.04.016.1	Yoke	Joch schw.	1
3	152156507-520.04.040.0	Bar	Stange	1
4	153284109-535.04.125.0	Bar 1	Stange geschw. 1	1
5	152157409-520.04.052.0	Bow	Bogen	1
6	152157506-520.04.053.0	Bow additional	Tragbogen	1
7	152157800-520.04.056.0	Lever	Hebel	1
8	152158006-520.04.057.0	Stirrup	Schäkel	1
9	152158202-520.04.058.0	Bolt	Bolzen	1
10	152158300-520.04.059.0	Wheel	Walzenrad	1
11	152158505-520.04.061.0	Protector	Sicherung schw.	1
12	152158809-520.04.064.0	Yoke	Gabel schw.	1
13	152159103-520.04.067.0	Tap	Schraubstöpsel	1
14	152159201-520.04.068.0	Spring	Druckfeder	1
15	152159309-520.04.069.0	Roll	Walze	2
16	152159407-520.04.070.0	Pin	Hülse	2
17	153283903-535.04.123.0	Bow	Sicherungsbogen	1
18	153146411-535.04.075.1	Tube	Rohr schw.	1
19	153147106-535.04.079.0	Screw	Schraube schw.	1
20	152160501-520.04.080.0	Link	Band schw.	1
21	152160805-520.04.083.0	Bolt	Bolzen	1
22	152160903-520.04.084.0	Bolt	Bolzen	1
23	152161001-520.04.085.0	Bolt	Bandbolzen	1
24	152161109-520.04.086.0	Yoke	Gabel	1
25	152161207-520.04.087.0	Bolt	Bolzen	1
26	152161305-520.04.088.0	Screw	Spannschraube	1
28	152546712-518.02.117.1	Bolt	Bolzen	2
29	152161706-520.04.092.0	Spring	Druckfeder	1
30	152161804-520.04.093.0	Bolt	Bolzen	1
31	152161902-520.04.094.0	Leg	Fuss	1
32	152162000-520.04.095.0	Spring	Druckfeder	1
33	152159808-520.04.096.0	Washer	Scheibe	1
35	152169502-520.04.102.0	Chain	Kette 2	2
36	152166114-520.00.001.1	Neck	Drehlager	2
37	152166202-520.00.002.0	Suport	Stütze	1
38	151048501-455.02.094.0	Safety wire clamp	Drahtsicherung	1
40	000210701	Screw M10x30	8.8 Zn SK Schraube M10x30	8.8 Zn 5
41	150170807	Screw M10x90	8.8 Zn SK Schraube M10x90	8.8 Zn 3
42	150067607	Screw M20x140	8.8 Zn SK Schraube M20x140	8.8 Zn 1
43	000221307	Nut M10	8 Zn SK Mutter M10	8 Zn 3
44	150275801	Nut M18x1,5	Cd Kronenmutter M18x1,5	Cd 4
45	000222208	Nut M20	8 Zn SK Mutter 20	8 Zn 1
46	000228408	Washer B10	Zn Federring B10	Zn 2
47	000251300	Washer A16	Zn Scheibe A16	Zn 1
48	159514705	Washer B18	Federring B18	4
49	150016100	Washer A24	Scheibe A24	1
50	159546002	Pin 3x40	Spannhülse 3x40	1
51	000232803	Pin 5x40	Spannhülse 5x40	2
52	000232402	Pin 5x24	Spannhülse 5x24	1
53	000234106	Pin 8x36	Spannhülse 8x36	1
55	000233704	Pin 6x50	Spannhülse 6x50	1
56	000235203	Pin 10x50	Spannhülse 10x50	1
57	000246905	Nipple A M10x1	Schmiernippel A M10x1	5
58	000246601	Nipple A M8x1	Schmiernippel M8x1	1
59	000240803	Cotter 6,3x40	Zn Splint 6,3x40	Zn 1
60	000239003	Cotter 4x25	Zn Splint 4x25	Zn 2
61	000240000	Cotter 5x32	Splint 5x32	4
62	150084009	Nut M10	SK-Mutter M10	5
63	152169600	Stirrup A 0,6	Zn Schäkel A 0,6	Zn 1
64	152169708	Clamp 8x80	Zn Karaninhacken 8x80	Zn 1
65	150040208	Nut M16	8 Zn SK-Mutter M16	8 Zn 3
66	152010807-516.05.026.0	Limiter	Begrenzenstück	1
67	152011003-516.05.032.0	Hook	Hacken schw.	1
68	152011405-516.05.037.0	Bolt	Bolzen mit gewinde	1
69	150008100	Screw M10x40	8.8 Zn SK Schraube M10x40	8.8 Zn 1
70	000228300	Washer B1	Federring B10	1
71	000228701	Washer B16	Federring B16	1
72	000221307	Nut M10	8 Zn SK-Mutter M10	8 Zn 1
73	150040208	Nut M16	8 Zn SK-Mutter M16	8 Zn 1
74	153147605-535.04.115.0	String L=5000	Treviraleine L=5000	1
75	152011600-516.05.040.0	Tube	Rohr	1
76	150019401	Clamp 9/11	Klemme 9/11	2
77	153147302-535.04.116.0	Eye	Uhr schw.	1
78	151633101-455.09.082.0	Ball	Kugel	1
80	151121002-M39.06.00.22	Spring	Zugfeder	1

Bild A

Fig. A

Bild A Fig. A

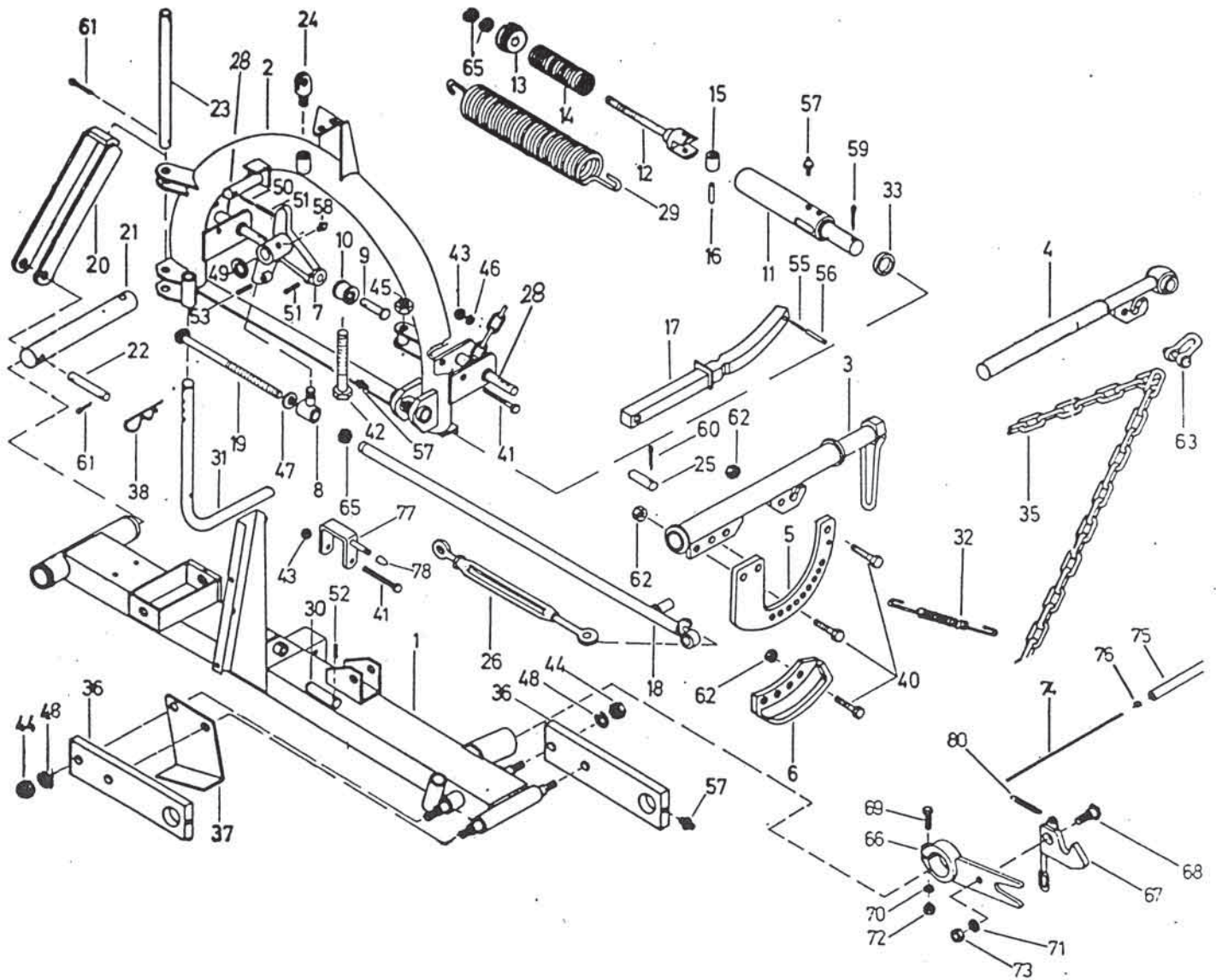

No. on the figure Numer anzeichn.	Catalogue no. Katalog nummer	Description	Benennung	Quantity Stück
1	152162412-520.03.001.1	Drive shaft	Antriebswelle	1
2	152162509-520.03.002.0	Gear-box housing	Gehäuse	1
3	152162705-520.03.003.0	Pulley	Riemenscheibe	1
4	152162901-520.03.004.0	Cover	Deckel	2
5	152163009-520.03.005.0	Sleeve	Büchse	1
6	152163107-520.03.006.0	Bolt	Bolzen	1
7	152163205-520.03.007.0	Tube	Distanzrohr	1
8	152163303-520.03.008.0	Spring	Druckfeder	1
9	152170108-520.02.017.0	Pulley	Riemenscheibe	1
10	152166300-520.00.005.0	Cover	Deckel	1
11	152166408-520.00.006.0	Inner protection	Schutz	1
12	152166515-520.00.007.1	Cuter protection	Schutz	1
13	152166603-520.00.008.0	Holder 1	Träger 1 schw.	1
14	152166809-520.00.010.0	Holder	Träger 2 schw.	1
15	151002408-455.05.051.0	Nut M30x1,5	Mutter M30x1,5	1
16	151002300-510.01.019.0	Protection washer	Sicherungsscheibe	1
17	152163401-520.03.009.0	Screw M16	Schraube M16	1
20	000248903	Screw M8x20 8.8	SK-Schraube M8x20	2
21	150106806	Screw M10x20 8.8 Zn	SK-Schraube M10x20 8.8 Zn	2
22	000221307	Nut M10 8 Zn	SK-Mutter M10 8 Zn	6
23	150040208	Nut M16 8 Zn	SK-Mutter M16 8 Zn	2
24	000228408	Washer B10 Zn	Federring B10 Zn	6
25	000251300	Washer A16 Zn	Federring A16 Zn	1
26	159804009	Vee-belt Bx3000	Keilriemen Bx3000	4
27	000244006	Bearing 6207 2 Z	Rillenkugellager 6207 2 Z	2
28	000256608	Key A10x8x50	Passfeder A10x8x50	1
29	000237602	Circlip 35 zun.	Sicherungsring 35 zun.	1
30	000235007	Pin 10x40	Spannhülse 10x40	1
31	000233508	Pin 6x40	Spannhülse 6x40	1
32	150051302	Pin 3,5x40	Spannhülse 3,5x40	1
33	153689002-520.03.110.0	P.T.O. Shaft protection	Gelenkwellesicherung	1

Bild B Fig B

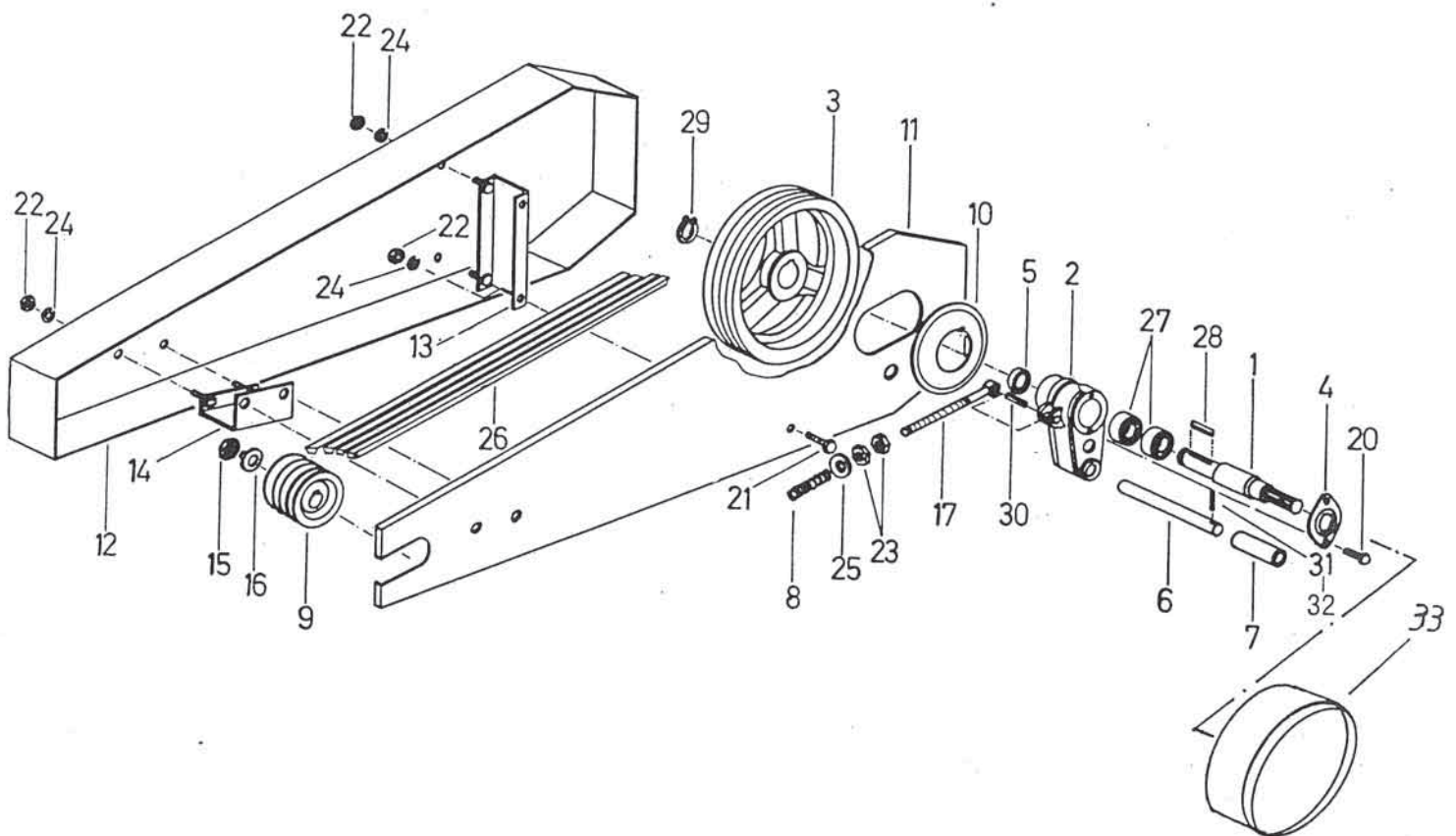

No.on the figure Numer anzeichn.	Catalogue no. Katalog nummer	Description	Benennung	Quantity Stück
1	152150416-520.02.001.1	Gear -box housingbg	Getriebegehäuse	1
2	152150601-520.02.002.0	Housing cover	Deckel	1
3	152150905-520.02.004.0	Housing cover	Deckel	1
4	152223614-520.02.005.1	Housing cover	Deckel	1
5	152151101-520.02.007.0	Gear	Kegelrad Z=16	1
6	152151209-520.02.008.0	Gear	Kegelrad Z=24	1
7	152151405-520.02.009.0	Shaft	Welle	1
8	152151502-520.02.010.0	Oil seal	Dichtung	1
9	152151600-520.02.011.0	Oil seal	Dichtung	1
10	152151708-520.02.012.0	Oil seal	Dichtung	1
11	152151806-520.02.013.0	Mix ring	Mischring	1
12	152151904-520.02.014.0	Control screw	Kontrolschraube	1
13	151019908-TN01	Distance washer	Distanzscheibe	1
14	151752106-150.08.006.0	Distance washer	Distanzscheibe	1
15	152150102-TN 01	Washer	Scheibe	1
16	151392709-455.04.039.0	Protection ring	Schutzring	1
17	152223702-520.02.006.0	Bolt	Bolzen	1
19	159194506	Seal 35x47x7	Dichtungsring 35x47x7	1
20	150158206	Seal 42x62x8	Dichtungsring 42x62x8	1
21	150026108	Screw M18x1,5 5.6	Verschlusschraube M18x1,5 5.6	1
22	000208509	Screw M8x15 8.8	SK Schraube M8x15 8.8	4
23	150158509	Screw M10x25 levi 8.8	SK Schraube M10x25 levi 8.8	1
24	000210701	Screw M10x30 8.8	SK Schraube M10x30 8.8	10
25	000230002	Washer A10	Zahnscheibe A10	1
26	000233606	Pin 6x45	Spannhülse 6x45	1
27	000233704	Pin 6x50	Spannhülse 6x50	1
28	000243105	Bearing 6206 2 RS	Rillenkugellager 6206	1
29	000251907	Bearing 6307	Rillenkugellager 6307	1
30	000230805	Key A8x7x50	Passfeder A8x7x50	3
31	000225009	Washer A20	Scheibe A20	1
32	000239806	Cotter 5x28	Splint 5x28	1
33	150127801	Circlip Z 38	Gimerungsring 38	1

Bild C

Fig C

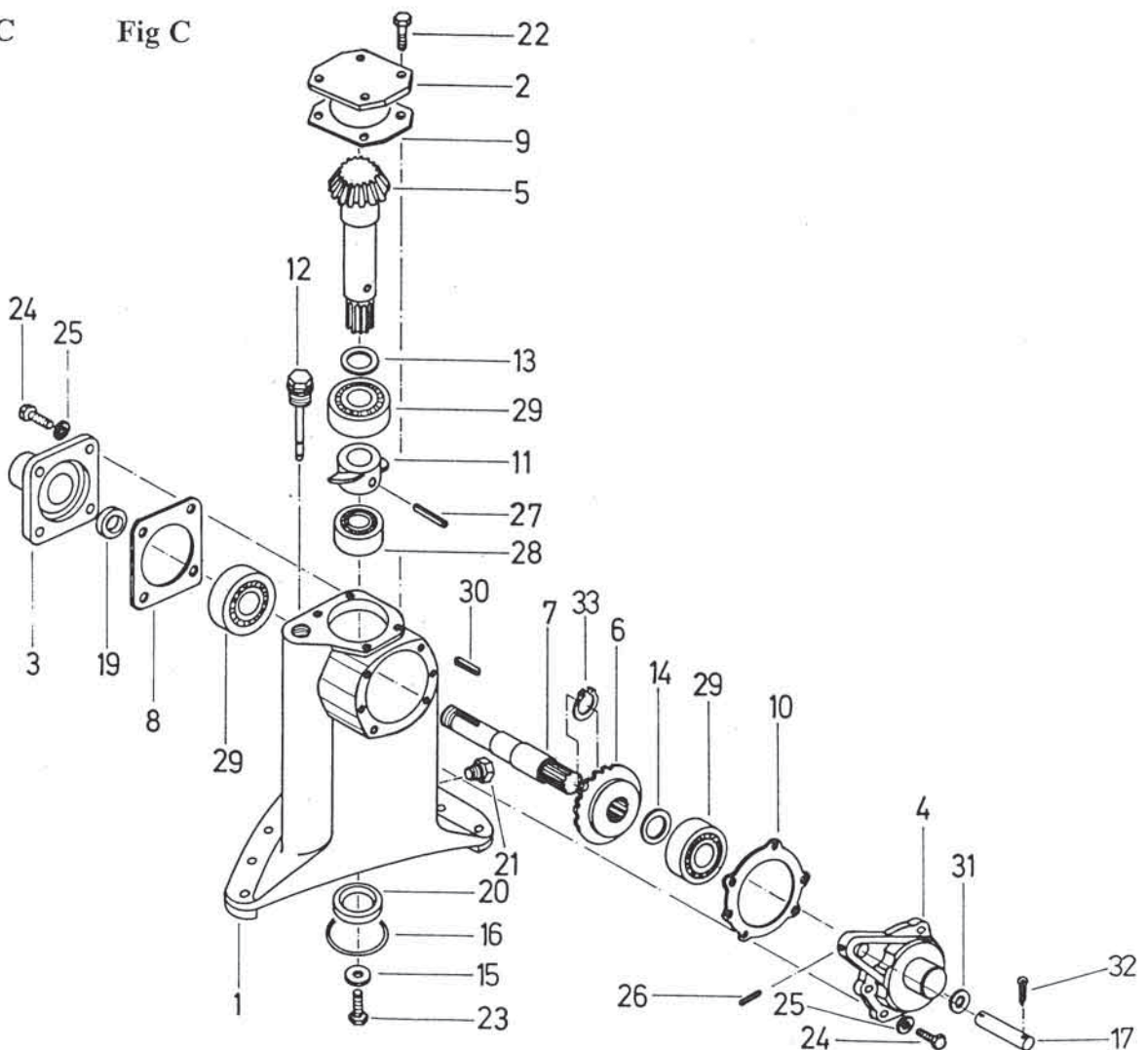

No.on the figure Numer anzeichn.	Catalogue no. Katalog nummer	Description	Benennung	Quantity Stück
1	154204006-534.01.001.0	Trough upper	Trog-obere schw.	1
2	152144816-520.01.009.1	Trough upper	Trog-untere schw.	1
3	152147803-520.01.042.0	Gear 29/4	Zahnrad 29/4	1
4	152148117-520.01.044.1	Gear 34/4	Zahnrad 34/4	4
5	152148518-520.01.047.1	Gear	Zahnrad 40/4	5
6	152148704-520.01.048.0	Gear 36/4	Zahnrad 36/4	2
7	152148900-520.01.049.0	Flange	Flansche	4
9	152149214-520.01.051.1	Protector	Sicherung	4
10	152149302-520.01.052.0	Cover	Deckel	1
11	152149400-520.01.053.0	Reinforlement	Schoner	1
12	152149605-520.01.054.0	Nut l.	Mutter links	2
13	152149703-520.01.055.0	Nut r.	Mutter rechts	2
14	150275400	Nut M10	SK Mutter M10	7
15	152149909-520.01.057.0	Plate	Verschlussplatte	4
17	152148303-520.01.045.0	Cotter pin	Sicherungsdraht	21
18	152150200-520.01.060.0	Gasket	Dichtung	1
20	000210701	Screw M10x30	SK Schraube M10x30	7
21	150158705	Bearing 6207-2RSN	Rillenkugellager 6207-2RSN	7
22	159540302	Bearing 3306	Schrägkugellager 3306	4
23	150158206	Oil seal 42x62x8	Achsichtring 42x62x8	4
24	159061702	O-ring 27,5x2,4	O-Ring 27,5x2,4	1
25	000246601	Nipple A M8x1	Schmiernippel A M8x1	4
26	000207608	Screw M6x15	SK Schraube M6x15	4
27	000208509	Screw M8x15	SK Schraube M8x15	24
28	000211005	Screw M10x35	SK Schraube M10x35	2
29	152712309-520.01.080.0	Screw M10x45	SK Schraube M10x45	1
30	000202300	Screw M10x60	SK Schraube M10x60	8
31	150330902	Screw M8x30 12.9	SK Schraube M8x30 12.9	4
32	000220905	Nut M8	SK Mutter M8	22
33	000221307	Nut M10	SK Mutter M10	11
34	000228300	Washer-Spring B10	Federscheibe B10	18
36	151186905	Washer	Scheibe	7

Bild D Fig. D

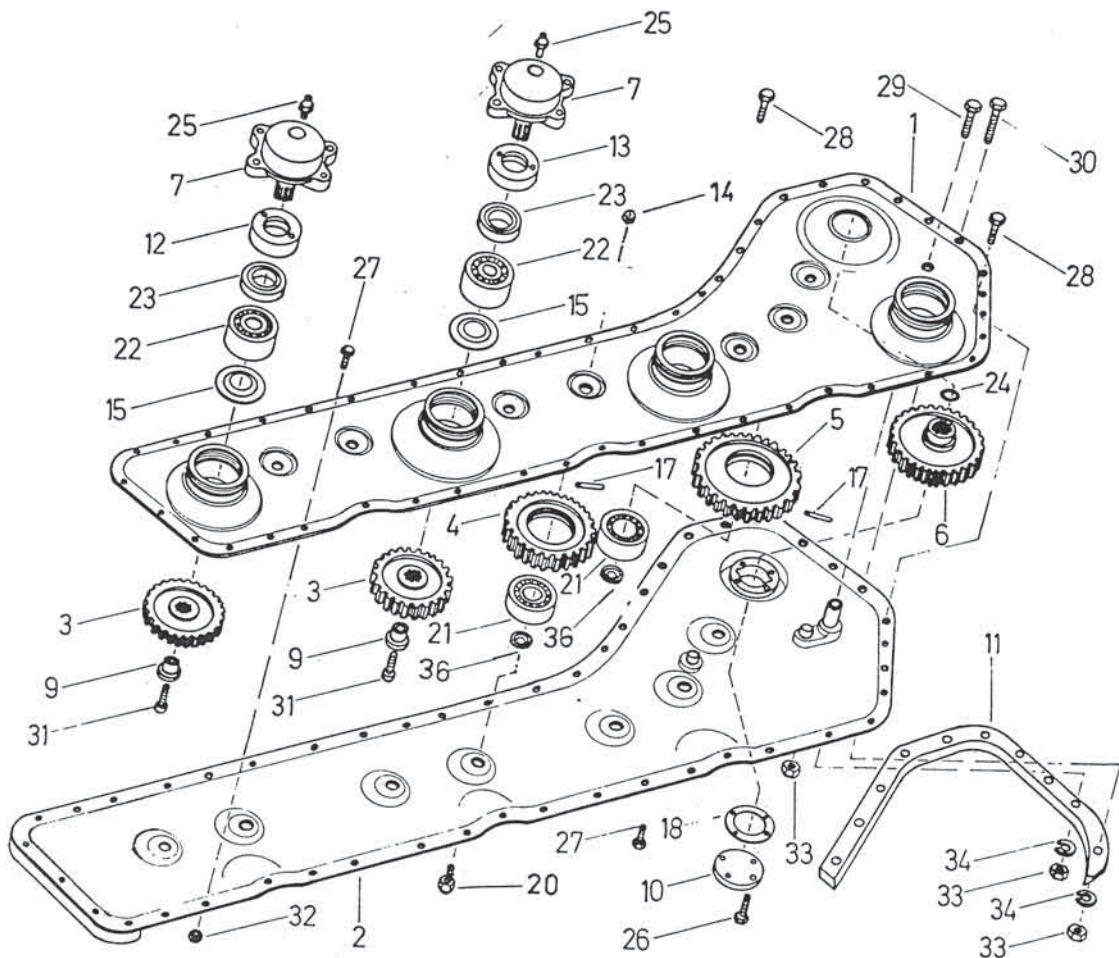

No. on the figure Numer anzeichn.	Catalogue no. Katalog nummer	Description	Benennung	Quantity Stück
1	152145501-520.01.015.0	Slider	Streifsohle schw.	1
2	152146001-520.01.022.0	Side	Streifsohle	1
3	153743603-534.01.020.0	Disc	Diskus	2
4	153744201-534.01.028.0	Disc	Diskus	2
8	153744906-534.01.035.0	Cover	Deckel	2
9	153744504-534.01.031.0	Cover	Deckel schw.	2
10	153744808-534.01.036.0	Flange	Flansche	2
11	000209205	Screw M8x30	SK-Schraube M8x30	8.8 Zn 4
12	150158304	Screw M8x40	SK-Schraube M8x40	8.8 Zn 10
13	150158402	Screw M8x45	SK-Schraube M8x45	8.8 Zn 2
14	000220905	Nut M8	SK-Mutter M8	Zn 16
15	000250800	Nut M8	SK-Mutter M8	5 Cd 12
16	150084009	Nut M10 8	SK-Mutter M10 8	5 Cd 8
17	000248805	Screw M12x35	SK Schraube M12x35	8.8 Zn 16
18	150192204	Screw M6x10	SK-Schraube M6x10	8.8 Zn 8
19	000228006	Washer B6	Federring B6	Zn 8
20	153171311-534.01.008.1	Knife left	Messer links	4
21	153171419-534.01.010.1	Knife right	Messer rechts	4
22	154005516-547.03.099.1	Knife screw	Messerträger	8

Bild E Fig. E

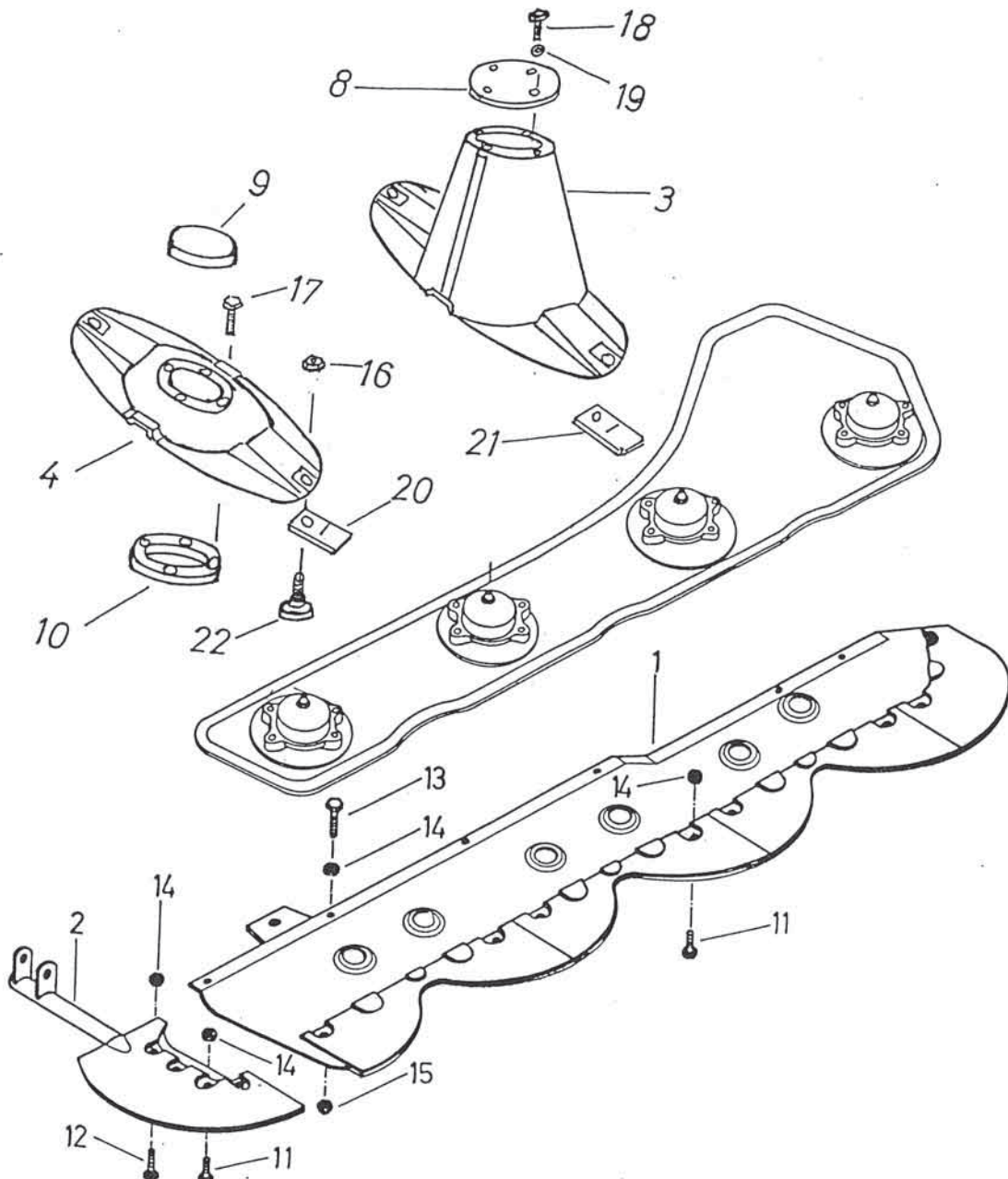

No. on the figure Numer anzeichn.	Catalogue no. Katalog nummer	Description	Benennung	Quantity Stück
	152169816-520-05.001.1	Hydraulic cylinder 22/225	Hydraulikzylinder 22/225	1
1		Guidance	Führung	1
2		Piston ro	Kolbenstange mit dem ohr	1
3		Cylinder	Zylinder	1
4		Piston	Kolben	1
5		Seal	Dichtring	1
6		O-seal	O-Dichtring	1
7		Seal	Dichtring	1
8		Scraper	Abstreifer	1
9		O-seal	O-Dichtring	1
10	150216000-4163-12	Cone seal	Konusdichtung	1
11		Nut	Mutter	1
12	159183705	O-seal 5x1,5	O-Dichtring 5x1,5	1
13		Pin	Gewindehülse	1
14	150275909-FADIP	Ruber tube V1 NP8x1800 A10 A20	Gumirohr V1 NP8x1800 A10 A20	1
15	150037800-FADIP	Gear- box C M22x1,5/M16x1,5	Reduzierstück C M22x1,5/M16x1,5	1
16	150108403	Pin AMD M22x1,5	Stecker AMD M22x1,5	1
17	152167103-520.05.002.0	Bolt	Bolzen	1
18	000252906	Washer A22x27	Dichtungsscheibe A22x27	1
19	000225009	Washer A20	Scheibe A20	1
20	000239806	Cotter	Splint	5
21	150121601	Holder 170	Kabelbinder 170	1
23	152616903-520.00.012.0	Holder	Träger schw.	1
24	152617109-520.00.014.0	Bolt	Bolzen	1

Bild G Fig. G

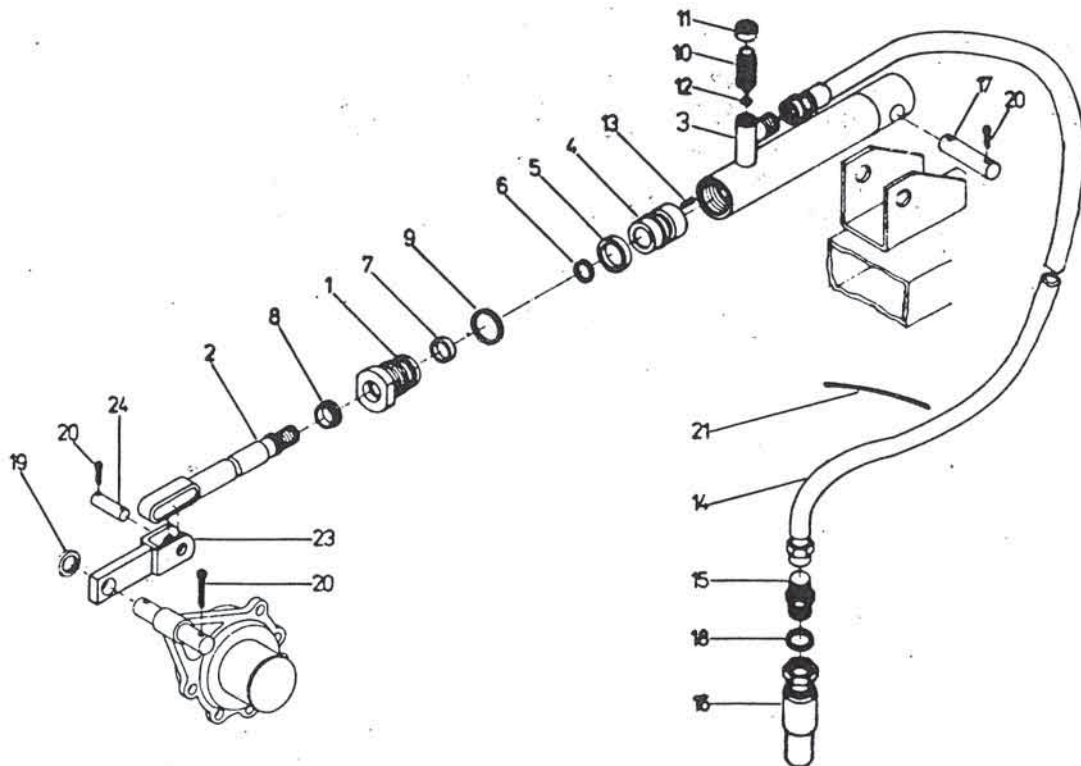

No. on the figure Numer anzeichn.	Catalogue no. Katalog nummer	Description	Benennung	Quantity Stück
1	153147909-535.06.001.0	Frame	Rahmen	1
3	153148301-535.06.006.0	Bolt	Bolzen schw.	1
4	152164703-520.06.012.0	Support	Stützbügel	1
5	152165604-520.06.022.0	Curtain	Fangschild 1	1
6	152165702-520.06.023.0	Curtain	Fangschild 2	1
7	152165800-520.06.024.0	Bolt	Bolzen	2
8	152165908-520.06.025.0	Handle	Hebel	1
9	152170000-520.06.026.0	String	Treviraleine	1
10	000240304	Cotter 5x50	Splint 5x50	1
11	151322900-250.00.002.0	Protector	Sicherung	1
17	000239003	Cotter 4x25	Splint 4x25	4

Bild F

Fig F

